



Optional internal V/I meter shown



Z367

◆ 24 Month Warranty

- High performance **DC UPS system**
- **No-Break** switching between charger & battery
- **Battery detection - regular battery presence and battery circuit integrity checks**
- **Alarm relay outputs**
- **LED flash codes for precise state indication**
- **Deep discharge protection for batteries**
- **ECB for battery overload & short circuit protection**
- **Fused reverse battery polarity protection**
- **Automatic temperature compensated output volts**
- **Option - battery condition test (BCT)**
- **Option - communication interface allows remote monitoring & user control of BCT function - i versions**
- **Batteries are external to the charger**

SPECIFICATIONS All specifications are typical at nominal input, full load and at 20 °C unless otherwise stated.

ELECTRICAL

Input voltage	230V AC: 180V - 264V (standard) 110V AC: 88V - 132V (on request)
Frequency	50/60 Hz
Fusing / protection	Input fuse plus varistor Battery fuse plus ECB for battery circuit
Isolation	1KV DC input - output / earth
Efficiency	≥ 85%
Inrush current	Soft start circuit
Output power	750W
Output voltage	13.8, 27.6, 34.5, 41.4, 55.2VDC
Voltage adj. range	85 - 105% of Vout
Temp. compensation	Temperature sensor on 1.7m lead with adhesive pad: -4mV / °C / cell ±10%
Current limits	PSU: 100% rated current Battery: 25-100% rated current (factory set)
Line regulation	<0.2% over AC input range
Load regulation	<0.4% open circuit to 100% load
Noise	<1%
Drift	0.03% / °C
Hold-up time	20 ms without battery (nominal - max. Vin)
Turn on time	< 2 sec
Thermal protection	Yes, self resetting
OVP	Over-voltage protection on output at ~ 130% of nominal output voltage
EMI	to CISPR 22 / EN55022 class A
Safety	to IEC950 / EN60950 / AS/NZS3260
Vibration	Designed to meet MIL-STD-810F Method 514.5

No-Break™ FUNCTIONS AND ALARMS

Reverse polarity protection	Battery reverse connection will open internal fuse (and produce alarm)
Battery monitoring	Detects for presence of battery on start up, then every 60 minutes when charge current < 200mA
Battery protection	Electronic circuit breaker (ECB) operates under the following conditions:
- low battery volts	<ul style="list-style-type: none"> • battery voltage drops to 1.67V/cell - auto reset
- overload	<ul style="list-style-type: none"> • < 300ms for load > 6 x rated PSU current, allows ~1.5x rated PSU current from battery without acting,
- short circuit	<ul style="list-style-type: none"> • < 2ms, backed up by fuse
Indication LEDs	Green: Battery System OK, Power OK Red: Standby
Alarms	<ul style="list-style-type: none"> • Power OK (alarm on mains fail) • Battery System OK - alarms when battery voltage low (on mains fail) , battery missing, battery circuit wiring faulty, BCT fail (if enabled)
Alarm relay contacts	C - NO - NC full changeover rated 1A /50V DC, 32VAC
Standby mode	Turns off DC output of PSU & allows load to run off battery
Battery condition test (BCT)	Enabled or disabled by user on SR750i - (20mins/28days). Optional for SR750C . BCT relay provided to control an external test load.

ENVIRONMENTAL

Operating temperature	0 to 50 °C ambient at full load De-rate linearly at >50 °C to zero @ 70 °C
Storage temperature	-10 to 85 °C ambient
Humidity	0 - 95% relative humidity non-condensing
Cooling	Fan cooled
Protection	IP20

750 Watt No-Break™ DC charger for lead acid batteries

SR750C

incl. SR750i

STANDARD MODEL TABLE

MODELS	DC Output				
	Output (V)	PSU Rated (A)	Charge Limit (A) *1	Recomm. Load (A)	Peak load on mains fail (A)
SR750C12	13.8	54	54	40	81
SR750C24	27.6	27	27	20	40
SR750C30	34.5	21	21	15	31
SR750C36	41.4	18	18	13	27
SR750C48	55.2	13.5	13.5	10	20

*1 This is the default setting. Please specify if a lower limit is required at time of order



Temperature Probe

SCHEMATIC BLOCK DIAGRAM

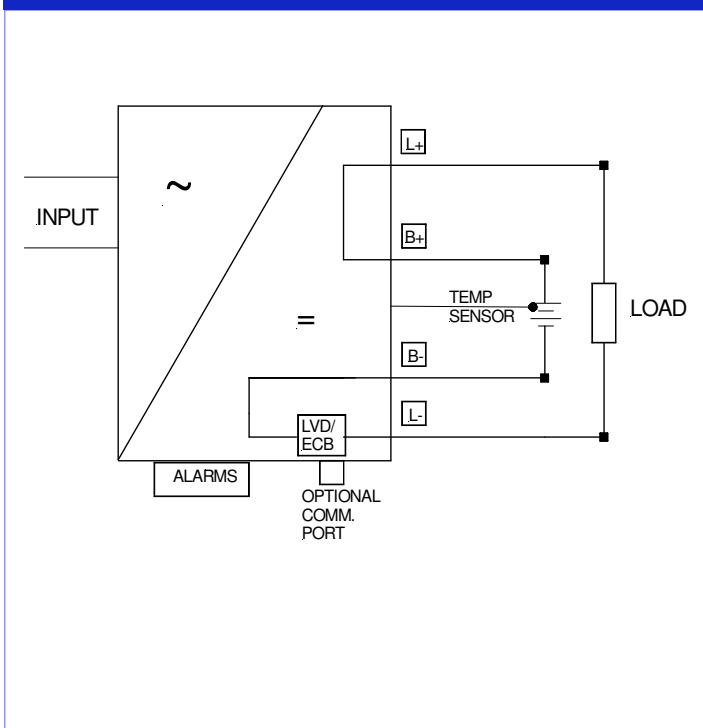

PHYSICAL

AC Input connector	IEC320 inlet socket (similar to PCs etc.)
DC Output Connections	M8 brass stud or plug-in/ screw terminal block
Alarm Connections	Plug in/ screw terminal block
Enclosure	Powder coated steel
Weight	4.3kg
Dimensions	225W x 304D x 70H mm (excluding mounting feet and terminals)

OPTIONS

19" Rack Mount	2U sub rack option: add SR-RM2U
Digital V/I meter	May be fitted with SR750 in 19" rack, add: SR-METER or SR-METERV2/SHUNT
Wall Mount Enclosure	Charger may be fitted into enclosure with MCBs and terminals. Code: SEC-SR
Parallel redundancy	Use external output diode, eg +P50
Internal V/I Meter	Add code +INT-METER
Communications Port (SR750i...)	Choice of RS485, RS232, Ethernet
Protocols	<ul style="list-style-type: none"> • SNMP v1 • Modbus (external converter) Serial: +PROTOCONMB TCP & HTTP: +PROTOCONMB-OE

ACCESSORIES SUPPLIED

Mounting feet together with screws
AC power cord 1.5m with IEC320 socket & AUS/NZ plug
Mating screw terminal plug for 'X' version
Mating screw terminal plug for alarm outputs
Crimp lugs for 'S' versions

MODEL IDENTIFICATION CODES

SR750C 12 T F S L-LAN+

