

# SHP650-1000 SERIES

AC/DC Single Output: 650 ~ 1200 Watts



## Features

- Rugged Industrial Construction
- Variable Fan Speed for Noise Reduction
- -20 °C to +70 °C Operation
- AC OK, Remote On/Off and Active Current Share
- 5 V Standby
- Screw Terminals

## Specification

### Input

Input Voltage	• 650 W: 80-264 VAC, derate output power 10% <90 VAC, and 20% <85 VAC 1000 W: 85-264 VAC, derate output power 10% <90 VAC
Input Frequency	• 47-63 Hz
Input Current	• 650 W: 6.5 A at 115 VAC typical, 3.2 A at 230 VAC full load, 1000 W: 10.9 A at 115 VAC typical, 5.1 A at 230 VAC full load
Inrush Current	• 650 W: 40 A max at 264 VAC 1000 W: 60 A max at 264 VAC
Power Factor	• >0.9
Earth Leakage Current	• 0.75 mA max 264 VAC/60 Hz
Input Protection	• 650 W: T16 A/250 V, 1000 W: T20 A/250 V internal fuse in line and neutral

### Output

Output Voltage	• 12-48 VDC (see tables)
Output Voltage Trim	• $\pm 10\%$ V1
Initial Set Accuracy	• 650 W: $\pm 1\%$ V1, $\pm 5\%$ V3, 1000 W: $\pm 1\%$ V1, $\pm 5\%$ V2
Minimum Load	• No minimum load required
Start Up Delay	• 500 ms max
Start Up Rise Time	• 50 ms typical
Hold Up Time	• 20 ms minimum
Drift	• $\pm 0.2\%$ after 20 min warm up
Line Regulation	• $\pm 0.5\%$
Load Regulation	• 650 W: $\pm 1\%$ V1, $\pm 5\%$ V3, 1000 W: $\pm 1\%$ V1, $\pm 5\%$ V2
Transient Response	• 4% max. deviation, recovery to within 1% in 500 $\mu$ s for a 50-75-50% load change
Ripple & Noise	• 1% pk-pk V1, 20 MHz bandwidth
Overvoltage Protection	• 115-145% Vnom, recycle input to reset
Overload Protection	• 110-140%, V1 only
Overtemperature Protection	• Auto reset
Short Circuit Protection	• Constant current characteristic
Temp. Coefficient	• 0.05% / °C
Remote Sense	• Compensates for 0.5 V total voltage drop
Remote On/Off	• Uncommitted isolated optocoupler diode, powered diode inhibits V1 and fan supply <sup>(1)</sup>
Current Share	• Single wire current share <sup>(1)</sup>

### General

Efficiency	• 85% typical
Isolation	• 3000 VAC input to output, 1500 VAC input to ground, 500 VDC output to ground
Switching Frequency	• PFC 70 kHz, main converter 200 kHz, standby 130 kHz typical
Power Density	• 650 W: 8.2 W/in <sup>3</sup> , 1000 W: 8.9 W/in <sup>3</sup>
Signals	• AC OK, remote on/off, current share <sup>(1)</sup>
MTBF	• 260 KHrs to MIL-HDBK-217F at 25 °C, GB

### Environmental

Operating Temperature	• -20 °C to +70 °C, derate linearly from +50 °C at 2.5% / °C to 50% at +70 °C, 1000 W: -40 °C start up
Cooling	• 650 W: Forced cooled, '-TF' & '-EF' models have integral dual voltage level fan, which is load dependant, U Channel requires 5.5 m/s minimum airflow, 1000 W: Forced cooled via integral quad voltage level fan which is load dependant <sup>(1)</sup>
Operating Humidity	• 95% RH, non-condensing
Storage Temperature	• -40 °C to +85 °C
Operating Altitude	• 3000 m
Shock	• 3 g pk, half sine, 6 axes
Vibration	• 2 g rms, 5 Hz to 500 kHz, 3 axes

### EMC & Safety

Emissions	• EN55022 class B conducted EN55022 class A radiated
Harmonic Currents	• EN61000-3-2 class A, 650 W: class C for loads $\geq 20\%$ 1000 W: class C for loads $\geq 10\%$
Voltage Flicker	• EN61000-3-3
ESD Immunity	• EN61000-4-2, level 3 contact, level 3 air, Perf Criteria A
Radiated Immunity	• EN61000-4-3, level 3 Perf Criteria A
EFT/Burst	• EN61000-4-4, level 3 Perf Criteria A
Surge	• EN61000-4-5, installation class 3, Perf Criteria A
Conducted Immunity	• EN61000-4-6, level 3, Perf Criteria A
Dips & Interruptions	• EN61000-4-11, 30% 10 ms, 60% 100 ms, 100% 5000 ms, Perf Criteria A, B, B
Safety Approvals	• IEC60950-1 CB report, CSA 22.2 No. 60950-1, UL60950-1, TUV, EN60950-1, SEMI F47

<sup>(1)</sup> See longform datasheet for more information

Output Voltage V1	Output Current V1	Fan Supply V2 <sup>(4)</sup>	Standby Supply V3	Output Power <sup>(3)</sup>	Model Number <sup>(1,2)</sup>
12 V	50.0 A	12 V / 0.5 A	5 V / 0.2 A	607 W	SHP650PS12-EF†^
15 V	40.0 A	12 V / 0.5 A	5 V / 0.2 A	607 W	SHP650PS15-EF†^
24 V	27.0 A	12 V / 0.5 A	5 V / 0.2 A	655 W	SHP650PS24-EF†^
28 V	23.0 A	12 V / 0.5 A	5 V / 0.2 A	655 W	SHP650PS28-EF†^
36 V	18.0 A	12 V / 0.5 A	5 V / 0.2 A	655 W	SHP650PS36-EF†^
48 V	13.5 A	12 V / 0.5 A	5 V / 0.2 A	655 W	SHP650PS48-EF†^

## Notes

- For top fan version replace '-EF' in model number with '-TF', e.g. SHP650PS12-TF
- For U Channel version remove suffix.

- U Channel models require a minimum of 5.5 m/s airflow from the system.
- Not available for '-TF' and '-EF' models as used by integral fan.

## Mechanical Details

### End Fan (See Longform Datasheet for U-Channel Version)

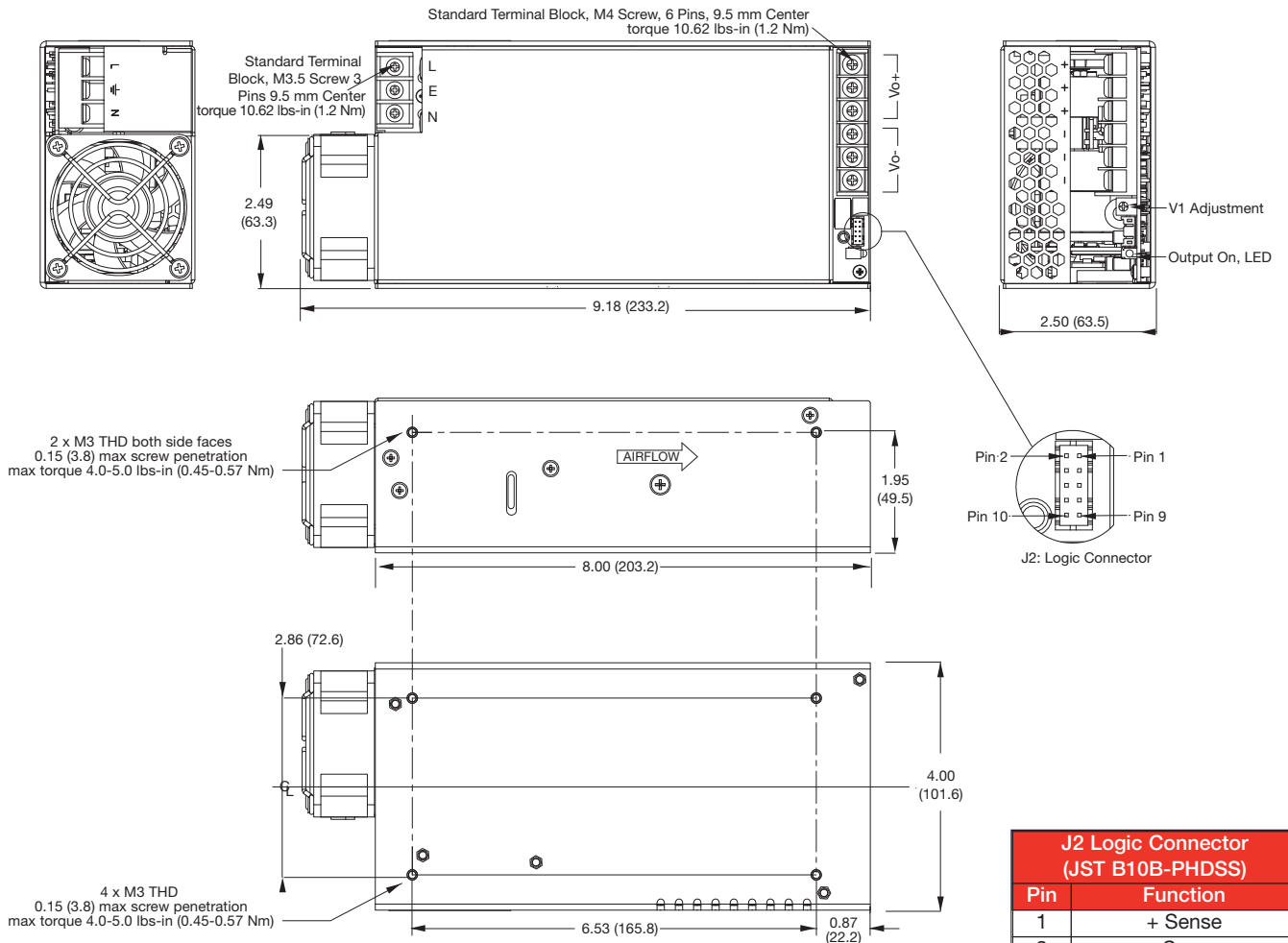

## Notes

- Dimensions shown in inches (mm).
- Weight: 2.8 lb (1.27 kg).

- J1 Mating Plug: JST part no. PHR-2, contact: JST part no. SPH-002T-P0.5S; J2 Mating Plug: JST part no. PHDR-10VS, contact: 26-22AWG JST part no. SPHD-001T-P0.5

# Mechanical Details

## Top Fan (Suffix -TF)

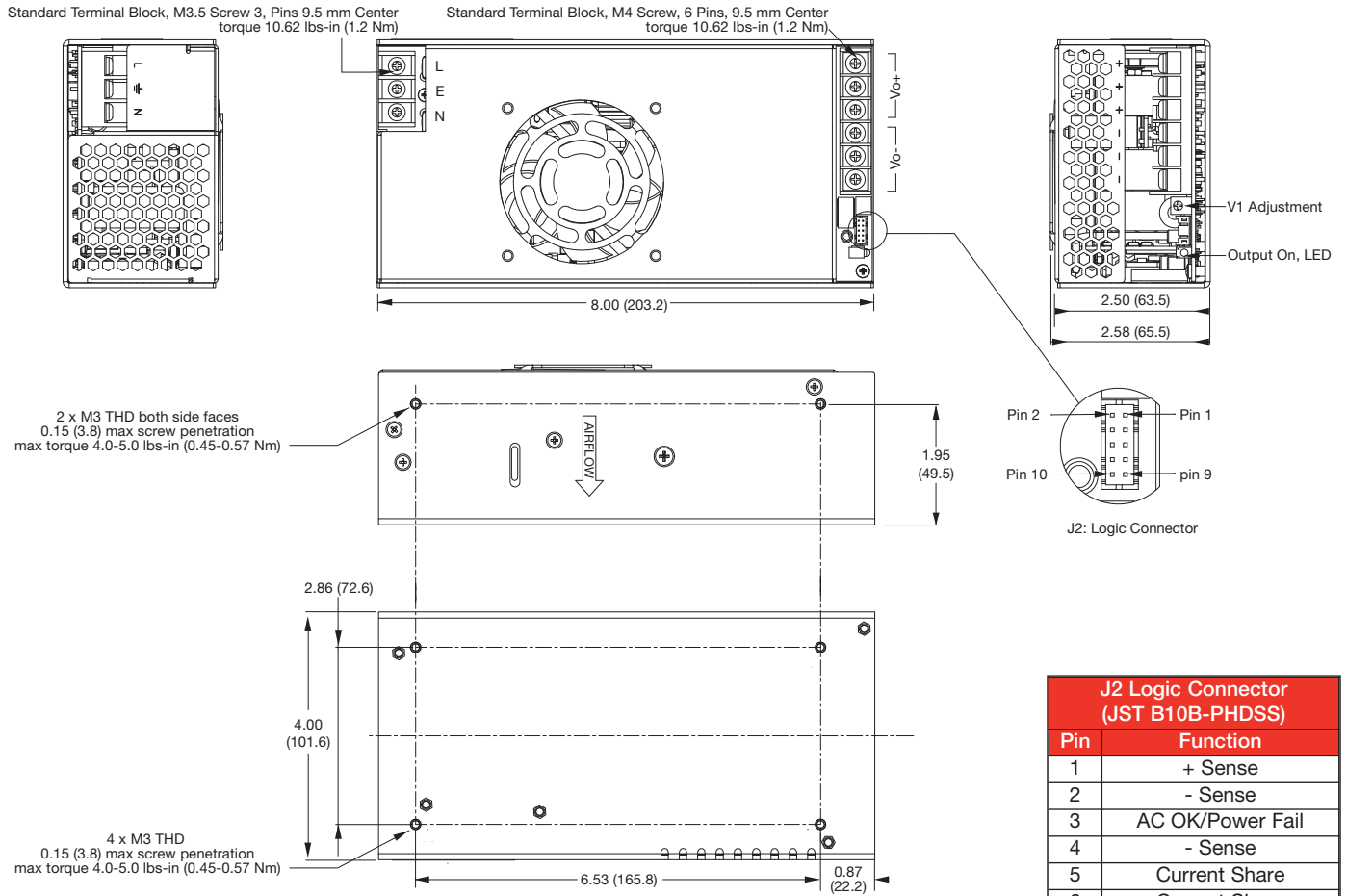

J2 Logic Connector (JST B10B-PHDS)	
Pin	Function
1	+ Sense
2	- Sense
3	AC OK/Power Fail
4	- Sense
5	Current Share
6	Current Share
7	+ Inhibit
8	- Inhibit
9	+5 V Standby (V3)
10	5 V Standby Return (V3)

### Notes

- Dimensions shown in inches (mm).
- Weight: 2.8 lb (1.27 kg).
- J2 Mating plug: JST part no. PHDR-10VS, contact: 26-22 AWG JST part no. SPHD-001T-P0.5.

## Signals

### AC OK/Power Fail

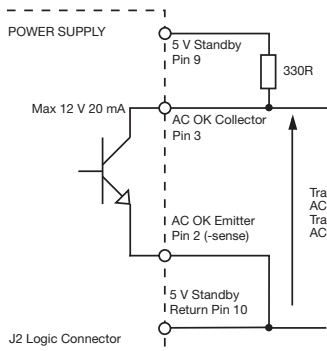

### Remote On/Off (Inhibit)

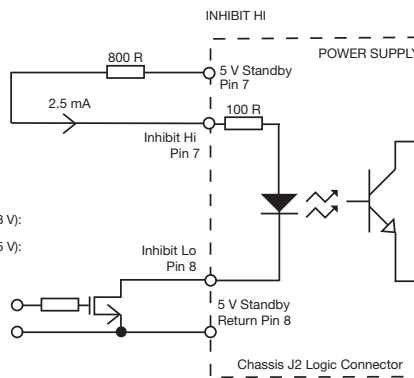

Signal High: Power Supply OFF  
Low or Floating: Power Supply ON

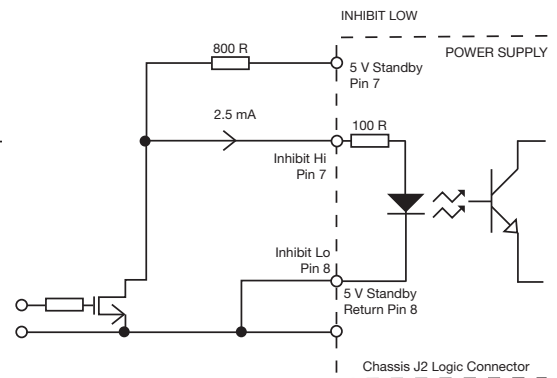

Signal High: Power Supply ON  
Low or Floating: Power Supply OFF

For U Channel and Thermal Considerations please see longform datasheet.

Output Voltage V1	Output Current V1		Standby Supply V2	Output Power		Model Number
	<180 VAC	>180 VAC		<180 VAC	>180 VAC	
12 V	83.0 A		5 V / 1.0 A	1000 W		SHP1000PS12†^
15 V	67.0 A		5 V / 1.0 A	1010 W		SHP1000PS15†^
24 V	42.0 A	50.0 A	5 V / 1.0 A	1013 W	1200 W	SHP1000PS24†^
28 V	36.0 A	43.0 A	5 V / 1.0 A	1013 W	1200 W	SHP1000PS28†^
36 V	28.0 A	34.0 A	5 V / 1.0 A	1013 W	1200 W	SHP1000PS36†^
48 V	21.0 A	25.0 A	5 V / 1.0 A	1013 W	1200 W	SHP1000PS48†^

## Mechanical Details

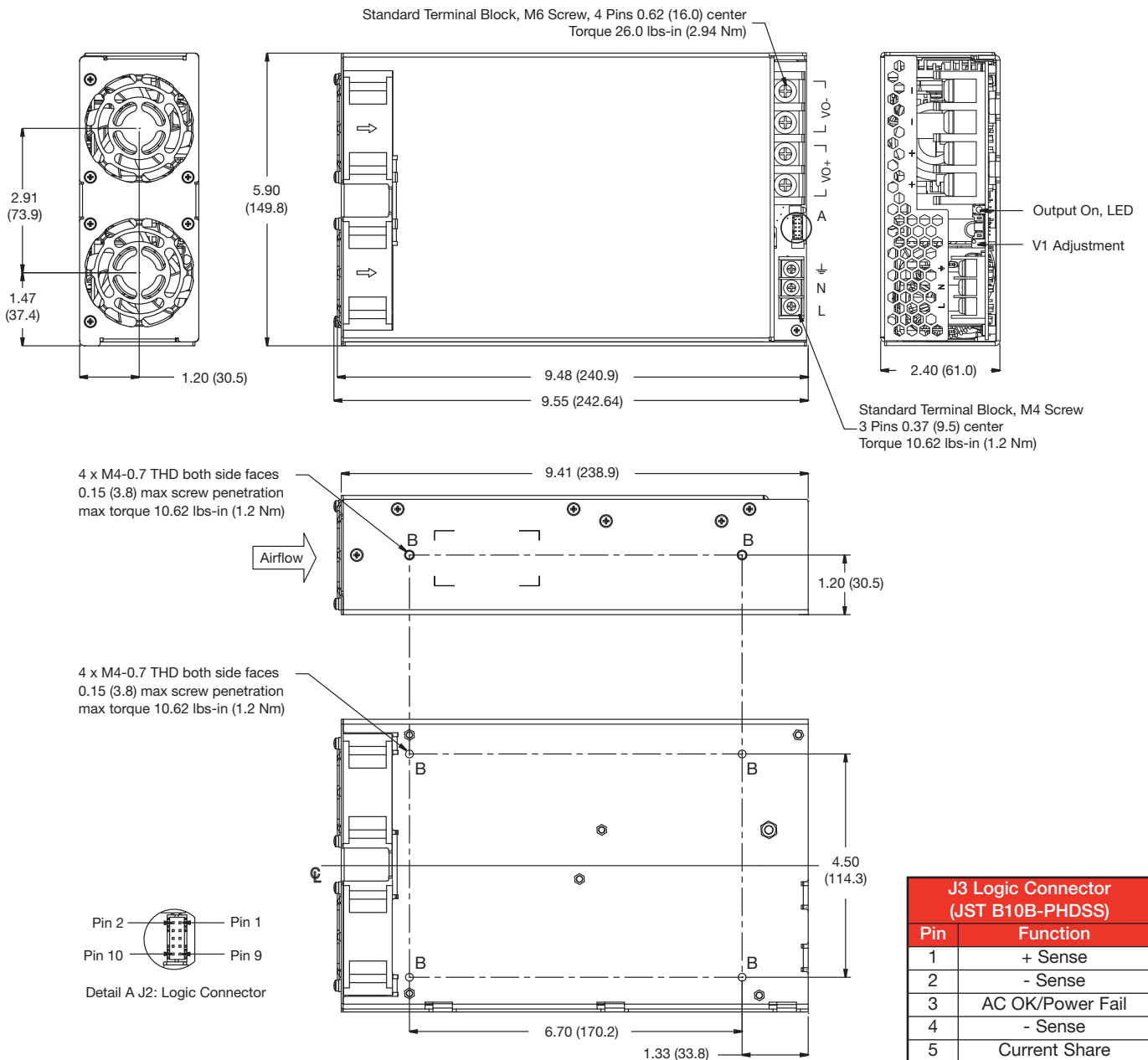

J3 Logic Connector (JST B10B-PHDSS)	
Pin	Function
1	+ Sense
2	- Sense
3	AC OK/Power Fail
4	- Sense
5	Current Share
6	Current Share
7	+ Inhibit
8	- Inhibit
9	+5 V Standby
10	-5 V Standby

### Notes

- Dimensions shown in inches (mm).
- Weight: 4.6 lb (2.08 kg)

- J2 Mating Plug: JST part no. PHDR-10VS, contact: 26-22AWG JST part no. SPHD-001T-P0.5