

# 100 AMP REDUNDANT ISOLATION MODULE



The ICT 100 Amp Redundant Isolation Module allows for a safe parallel connection of two DC power supplies or DC-DC converters to create an N+1 fault-tolerant redundant power system. In the unlikely event where one of the power supplies experiences an output short to ground failure, the ICT Redundant Isolation Module instantly disconnects the non-functioning power source to prevent the system bus voltage from falling, and prevents large reverse peak currents, which could cause damage to the remaining power supply.

ICT has implemented an active design approach using MOSFETs, which has the advantage of being smaller and lighter, more efficient with less conversion loss and heat buildup, and has less voltage drop than traditional ORing Schottky diodes. This addresses the primary downside to traditional ORing diodes, which is the high voltage drop and the increased power dissipation loss in the ORing diodes as power requirements for the system increases. This loss can be up to 10 times higher using a traditional ORing diode.

The ICT Redundant Isolation Module is designed to connect directly to the outputs of two ICT Digital Series or Pro Series power supplies, saving space and simplifying installation. It also comes with mounting flanges for mounting flexibility, and can be used with any matching DC power supplies or DC-DC Converters.

## ELECTRICAL SPECIFICATIONS

No. of Input Channels	2
Operating Voltage Range	5 to 65 Volts DC
Input Current Rating (max cont)	100 Amps DC
Output Current Rating (max cont)	100 Amps DC
Fault Detected Switchoff Time	< 2µs
System Ground	POS or NEG (consult manual)

## MECHANICAL

Length	5.3 inches (135 mm)
Width	3.4 inches (86 mm)
Height	0.95 inches (24 mm)
Input Connectors	Bus Bars (2) with 5/16" holes
Output Connector	Bus Bar (1) with 5/16" hole
Weight	0.6 lbs. (0.27kg)

## ENVIRONMENTAL

Operating Temperature Range	-40C to +60C(no derating)
Storage Temperature Range	-40C to +70C
Operating Environment	Indoor, Pollution Deg 2



The compact size of the ICT 100A Redundant Isolation Module allows it to be mounted directly to the output bus bars of two 1RU ICT Digital Series or Pro Series power supplies, saving valuable space and reducing the need for extra cabling.

OUTLINE DRAWING

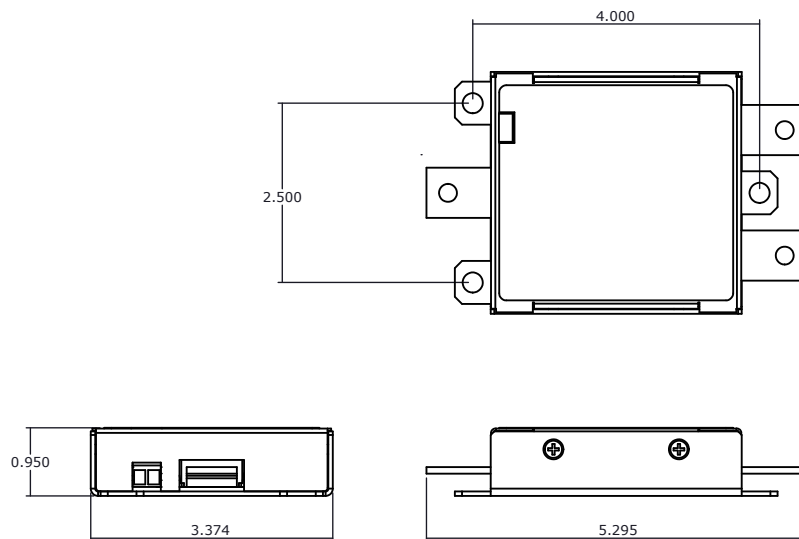

ORDERING INFORMATION

Description	Model Number
100 Amp Redundant Isolation Module for 12, 24 or 48 Volts DC	ICT100-RIM

ACTIVE DESIGN BENEFITS

An ORing device is a diode that protects the system against an input power source fault condition. The diode allows current to flow in one direction only, thus isolating the fault from the redundant bus, allowing the system to continue to run from the remaining power supply. Traditional passive ORing diodes are characterized by large size, high conversion and line losses, and bulky heat sinking required to dissipate the built-up heat.

In an active ORing solution the ORing diode is replaced with a combination of a power MOSFET and a microcontroller. Unlike traditional ORing diodes, active designs do not require any additional heat sinking or external cooling, as they are up to 10 times more efficient than diodes. This allows the package to be much smaller and lighter.

In addition to the extremely low power losses, active designs provide fast dynamic response to fault conditions, critical for high availability power systems.