

BCH300-500 SERIES

Battery Chargers: 300 ~ 500 Watts

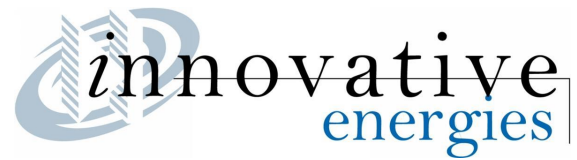

AC Input: Terminals
(STD model)

AC Input: IEC socket
(Option)

Specifications

Input Voltage	230VAC (190 ~ 264)
Input Frequency	47 ~ 63Hz
Input Current	BCH300 @ 2.8A, BCH500 @ 4.7A
Input Protection	Inrush current limiting Transient protection / Varistors Internal safety fuse
Isolation	Input – Output: 4300vdc Input - Chassis 2250vdc Output – Chassis 500vdc
Efficiency	Typically 80%
Output voltage	See table
Output Power	300 ~ 500 watts
Voltage adjustment	12V: 12-14V. 24V: 24-28V 48v: 48-56V 96v: 108-127V 108V: 108-127V
EMC	EN55022 Class A
Immunity	EN 61000-4-2 (ESD) EN 61000-4-3 (RF Immunity) EN 61000-4-4 (Fast Transients) EN 61000-4-6 (Conducted Imm.)
Switching Freq.	Typically 55KHz
Output Diode	Internally fitted output isolation diode
Parallel operation	Yes
Regulation	Line: ±1% Load: ±1.5%
Output Ripple/Noise	Typically <1% of output voltage
Overload Protection	Constant current limiting with short circuit protection. Battery must be externally fused.
Thermal Protection	Thermal shutdown with auto recovery, when unit cools down.
Overvoltage Protection	Yes. Recycle mains input to re-set
Operating Temp.	0°C to +50°C at full load. Derate 2.5% per °C to +70°C.
Temperature Drift	0.03% per °C over operating range

Features

- Convection cooled: No fans
- Two power levels: 300 & 500 watts
- Fully isolated input – output
- Over voltage protection
- Overload and short circuit protection
- MTBF > 150,000hrs
- Any output from 12vdc ~ 120vdc possible
- Customised mechanical solutions on request
- Power Fail / Charger Fail Alarm
- Battery Low Alarm
- Temperature Compensation Charging - option
- **IEC Socket input option** for AC Power:
- add “-IEC” to model

Description

The **BCH300 & BCH500** series battery charger is a rugged, industrial-grade product, using field- proven design suitable for use in DC battery back-up applications.

It is a mature product providing excellent reliability and performance and delivering 300 / 500 watts of output power with convection/conduction cooling. ...NO Fans.

The two alarms provide external monitoring of Power Fail / Charger Fail and Battery Low via voltage free contacts. The chassis-mount design feature allows for easy mounting.

Additional ruggedizing and conformal coating are available for applications requiring higher immunity to shock, vibration, humidity, moisture, dust and insects.

Options

TBC	Temperature Battery Compensation Charging
TIM	Automatic Battery Testing
Boost	A variety of boost options
IEC	AC input via IEC socket & power cord
Rack Mount	19in Rack Mount options

Specifications Cont.

Cooling	Conduction / convection cooled via base plate.
Shock & Vibration	IEC61373 Cat 1 A&B
Humidity	5-95% non-condensing
MTBF	>150,000hrs @ 45°C
Indicator	Green LED visible through cooling slots
Alarm Output	<ul style="list-style-type: none">• Power Fail / Charger Fail Alarm• Low Battery Alarm Both Alarms are CLOSE FAIL with common return Low battery only operative if power / charger fails.
Connections	Terminal block / barrier strip with 3/8" spacing
Dimensions	BCH300: 290 x 132 x 62mm (F3) BCH500: 352 X 132 X 62mm (F4)
Weight	BCH300 / BCH500: 2.0 / 2.5kg

BCH300-500 SERIES

Battery Chargers: 300 ~ 500 Watts

Model	Output			Power W
	Nom V	Float V	A	
BCH300-14FT	12V	13.8V	20A	300W
BCH300-28FT	24V	27.6V	11A	300W
BCH300-55FT	48V	55.2V	5.5A	300W
BCH300-110FT	96V	108.0V	2.5 A	300W
BCH300-110FT	108V	124.0V	2.5A	300W

110V model adjustable for use on 96V or 108V nominal battery systems

Model	Output			Power W
	Nom V	Float V	A	
BCH500-28FT	24V	27.6V	18A	500W
BCH500-55FT	48V	55.2V	9A	500W
BCH500-110FT	96V	108.0V	4.0A	500W
BCH500-110FT	108V	124.0V	4.0A	500W

110V model adjustable for use on 96V or 108V nominal battery systems

BCH300

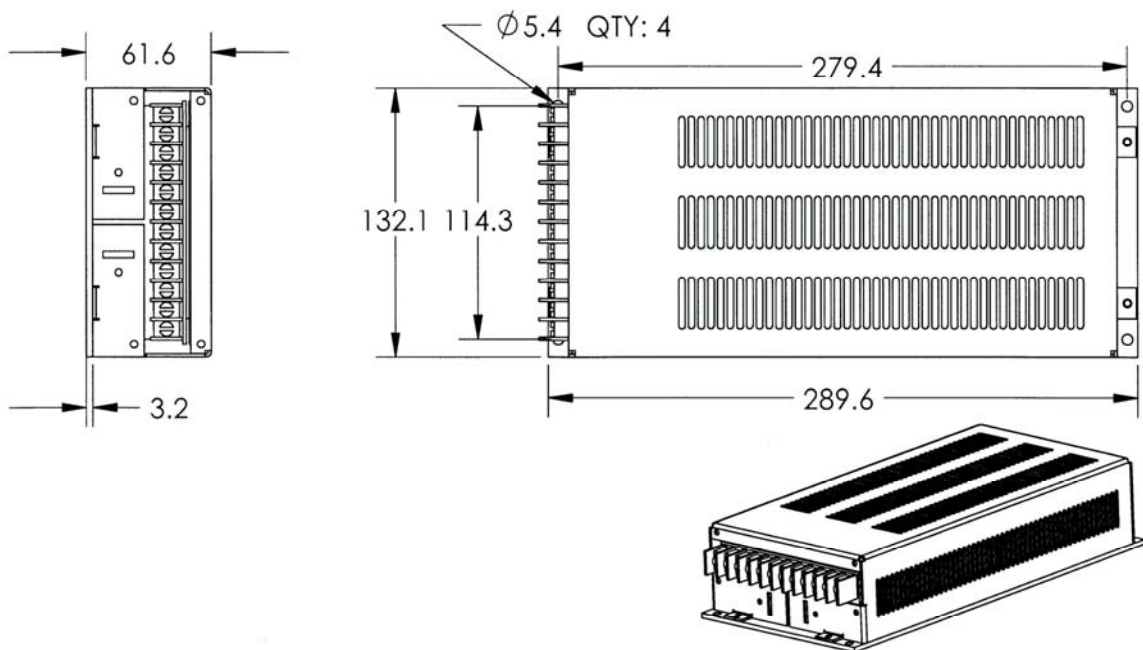

BCH500

