

DC-DC Converter AVP/Js and AVP/Jsp

Output power up to 53 Watts

Isolated - Single Output
PCB (AVP/Jsp) and Chassis Mounting (AVP/Js)

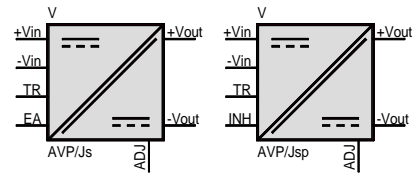

Technology

- MOSFET design
- Regulators in surface mount technology

Special Features

- Series meets Generic Immunity Standard according to EN 50082-2:1995 with additional improvements, criterion A:
 - Burst transients: Input and output filtering according to EN 61000-4-4:1995 (class 3): 2 kV
 - Surge: Input and output filtering according to EN 61000-4-5:1995 (class 2): 1kV symmetric
 - Electrostatic discharge according to EN 61000-4-2:1995 (testing level 4): 8 kV contact (base plate)/15 kV air
- Conducted RFI:
 - Input filtering according to EN 55022:1994, class B
 - Output filtering according to Vfg 243/1991
- Reverse polarity protection
- Zero load operation and short circuit protected
- Parallel and series connection
- Overtemperature shutdown
- No overshoot of output voltage at switching on
- Remote off (inhibit) with TTL - L-signal
- Overvoltage protection in the output circuit, even in case of external supply (OVP)
- Extremely low thermal stress of sensitive components due to dissipated power loss over mounting surface
- Vibration resistant and indifferent to humidity due to encapsulated case

Specifications

at $J_{amb} = 25^{\circ}\text{C}$, $U_{in\ nom}$, $0,62 I_{out\ nom}$

Temperature

Ambient air	$J_{amb} = -40...+85^{\circ}\text{C}$
Storage	$J_S = -40...+100^{\circ}\text{C}$
Rise in case	$DJ_{C\ perm} \leq 20\ \text{K}$
Permissible rise on base plate	$DJ_{K\ perm} \leq 25\ \text{K}$
Necessary thermal resistance of mounting surface (chassis) to ambient	$R_{thKA} \leq 4,5\ \text{K/W}$

Output voltages

Tolerance $DU_{out}/\%$ (AVP/Js)	$\leq \pm 0,25\ (0,5)^*$
Output ripple u_{out}/mV_{rms} at $J_{amb} = -40^{\circ}\text{C}...+85^{\circ}\text{C}$	$\leq 3,5$
Temperature coefficient $TC\%/K$	$\leq 0,16$

Regulation at $J_{amb} = -40^{\circ}\text{C}...+85^{\circ}\text{C}$

Line regulation DU_{out}/mV for 100% DU_{in}	≤ 2
Load regulation DU_{out}/mV per A load static	$\leq 10^{***}$
DU_{out}/mV per A load change (25°C)	$\leq 85\ (40)^{***}$

OVP

Starting point $U_{out\ nom}/\%$	≤ 130
admissible continuous external current I_{ext}/A	$\leq 4,5$

Isolation voltage-strength

In-/Output U_{rms}/kV	$\geq 1,5$
Input to base plate U_{rms}/kV	$\geq 1,5$
Output to base plate U_{rms}/kV	$\geq 0,5$
Resistance R_{iso}/Ω	$> 10^{11}$
Capacitance C_{iso}/pF	$= 2200$

Weight AVP/Js / AVP/Jsp M/g = 220/200

Block diagram

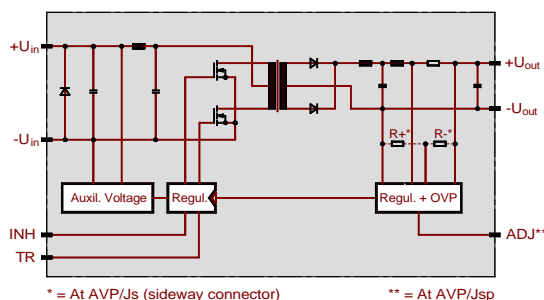

* At 5 V double values.

** At the AVP/Jsp 9 mV smaller values.

*** $I_{out\ min} = 0,1 I_{out\ nom}$. At the AVP/Jsp 5 mV smaller values.

Drawings

Dimensions in mm with a outside dimensions tolerance of + 1 mm

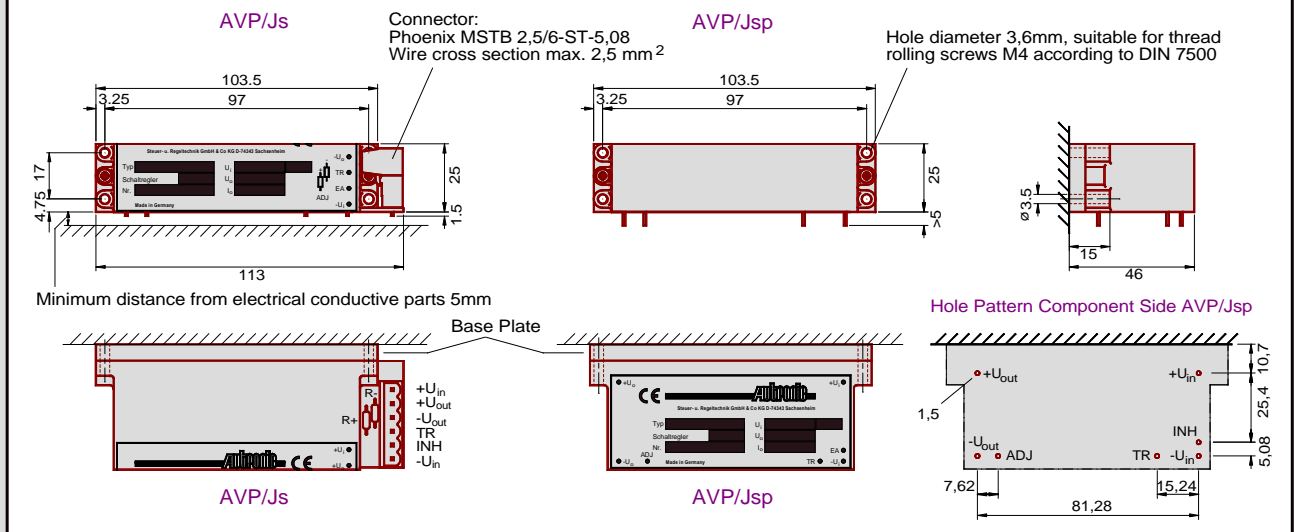

Operating instructions:

Installation: The converters have to be installed according to the guidelines currently in force, like other open electronic component assemblies. Attention must be paid to sufficient ventilation, fastening and protection against accidental contact! The mounting surface has to be even with a thermal resistance as described under "Specifications". If more than one converter is mounted on the same mounting surface the thermal resistance has to be divided by the quantity of converters used. The base plate has to be grounded by using thread rolling screws M4 according to DIN 7500.

Reverse polarity protection: If reverse polarity connection of the input voltage can not be excluded, an external time-lag fuse must be installed. Size: $I_{rat} = 1,5 I_{in max}$ (max. 16 A). Pay attention on sufficient current of current source in case of short-circuit ($t_f < 300$ ms)!

Excess temperature protection: In case temperature exceeds 101°C, typ. 105°C, (due to inadmissible operation conditions) the output voltage is automatically switched off and restarted after cooling down about 10 K.

Overvoltage protection: Externally or internally caused overvoltage at the output leads to a thyristor-controlled short-circuit and shut-down of the output. After elimination of the overvoltage the output voltage restarts automatically.

External shut down (inhibit): $U < 0,8$ V at pin "INH" to pin $-U_{in}$ switches off the output. $I_{source} 500 \mu A$.

Current limiting: $I_{out lim} = 1,1...1,2 I_{out nom}$. At more than 50% overload, the output switches off and restarts automatically latest after 1s of elimination of the overload.

Tracking operation: If the TR pins of two or more converters are connected, the output voltages in case of short-circuit or overload go synchronously down.

Adjustment: Connection of the pins "ADJ" and $-U_{out}$ for the AVP/Jsp modules or inserting a wire to "R+" for the AVP/Js modules increases the output voltage of about 8%. Intermediate values are obtained by means of a resistor. By connecting "ADJ" and $+U_{out}$ pins for the AVP/Jsp by means of a resistor i.e. adding a resistor for "R-" for the AVP/Js ensure that the output may be lowered by max. 8%.

Standard converters AVP/Js and AVP/Jsp

$\frac{U_{out}}{V}$	$\frac{I_{out nom}^{**}}{A}$	$\frac{U_{in nom}}{V}$	$\frac{U_{in range}}{V}$	$\frac{I_{in max}}{A}$	$\frac{h^{***}}{\%}$	f kHz	Order Number	
							AVP/Js	AVP/Jsp
5*	4,8	12/24	5...36****	6,7	78	67	09 36 81 0112 2	09 36 81 0172 2
	6,4	12/24	9...40	4,8	81		09 36 61 0112 6	09 36 61 0172 6
	8,0	24	15...36	3,4	84		09 36 91 0112 9	09 36 91 0172 9
	8,0	48	32...74	1,6	82		09 36 51 0112 8	09 36 51 0172 8
	8,0	110	66...154	0,8	82		09 36 71 0112 4	09 36 71 0172 4
12	2,1	12/24	5...36****	6,7	79	67	09 36 82 0112 1	09 36 82 0172 1
	2,9	12/24	9...40	4,8	83		09 36 62 0112 5	09 36 62 0172 5
	4,0	24	15...36	3,7	88		09 36 92 0112 8	09 36 92 0172 8
	4,0	48	32...74	1,8	86		09 36 52 0112 7	09 36 52 0172 7
	4,0	110	66...154	0,9	86		09 36 72 0112 3	09 36 72 0172 3
15	1,6	12/24	5...36****	6,4	80	67	09 36 83 0112 9	09 36 83 0172 9
	2,2	12/24	9...40	4,6	84		09 36 63 0112 4	09 36 63 0172 4
	3,2	24	15...36	3,7	89		09 36 93 0112 7	09 36 93 0172 7
	3,2	48	32...74	1,8	86		09 36 53 0112 6	09 36 53 0172 6
	3,2	110	66...154	0,9	86		09 36 73 0112 2	09 36 73 0172 2
24	1,1	12/24	5...36****	7,2	80	67	09 36 84 0112 8	09 36 84 0172 8
	1,4	12/24	9...40	4,7	85		09 36 64 0112 3	09 36 64 0172 3
	2,1	24	15...36	3,9	89		09 36 94 0112 6	09 36 94 0172 6
	2,1	48	32...74	1,8	87		09 36 54 0112 5	09 36 54 0172 5
	2,1	110	66...154	0,9	87		09 36 74 0112 1	09 36 74 0172 1
30	1,0	12/24	5...36****	7,7	80	67	09 36 85 0112 7	09 36 85 0172 7
	1,3	12/24	9...40	5,1	85		09 36 65 0112 2	09 36 65 0172 2
	1,75	24	15...36	4,0	89		09 36 95 0112 5	09 36 95 0172 5
	1,75	48	32...74	1,9	85		09 36 55 0112 4	09 36 55 0172 4
	1,75	110	66...154	1,0	85		09 36 75 0112 9	09 36 75 0172 9

* Adjusted to 5,1 V

** For $\vartheta_{amb} = -40^{\circ}C...55^{\circ}C$. Derating from 55°C to 85°C: 1,25%/°C, I_{out} between 85°C and 95°C linear decreasing to 0 A.

*** At $U_{in nom}$ and 0,6 $I_{out nom}$

**** Converter switches on at $U_{in} > 8$ V

In case of operation at $U_{in} < 7$ V 10% basic load is required.

Specifications subject to change without notice

Innovative Energies Limited
1 Heremai St, Auckland, NZ
Telephone +64 9 8350700
Email: info@innovative.co.nz
http://www.innovative.co.nz